

# INSTRUCTIONS DE MONTAGE POUR LA BASE MOTRICE À ROUES BLEUES

Projet robotique en mathématique

Produit par :  
Maxime Poirier et Marie-Pier Bécharde





1

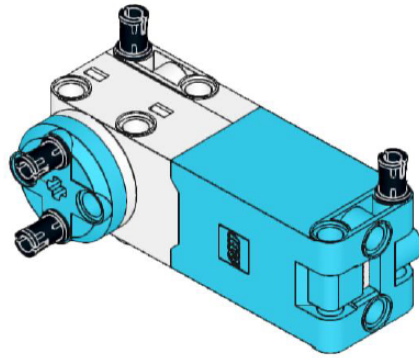
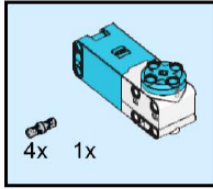

2

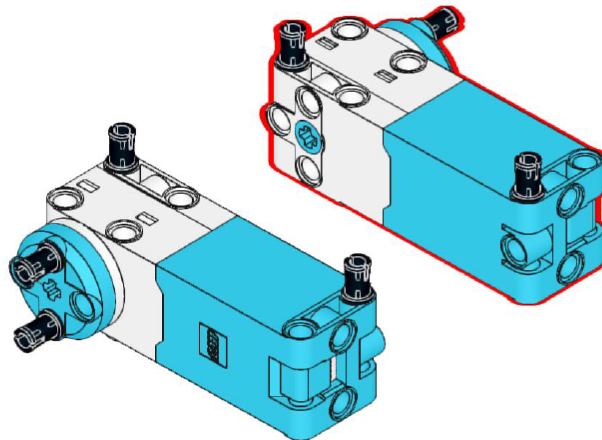
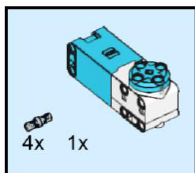



3

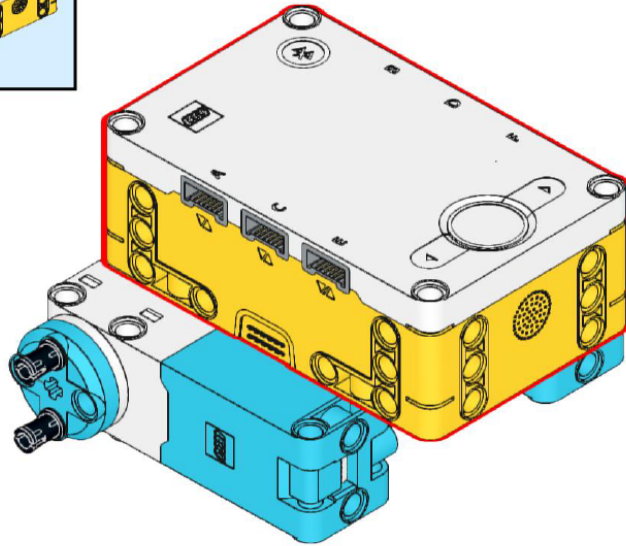
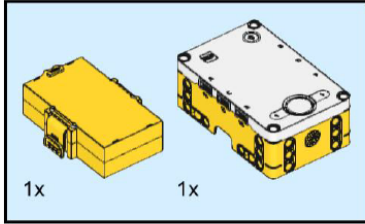

4

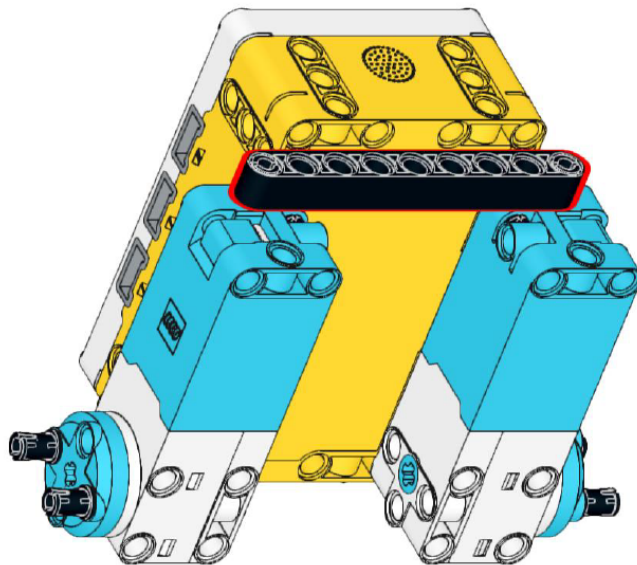
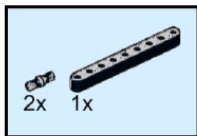



5

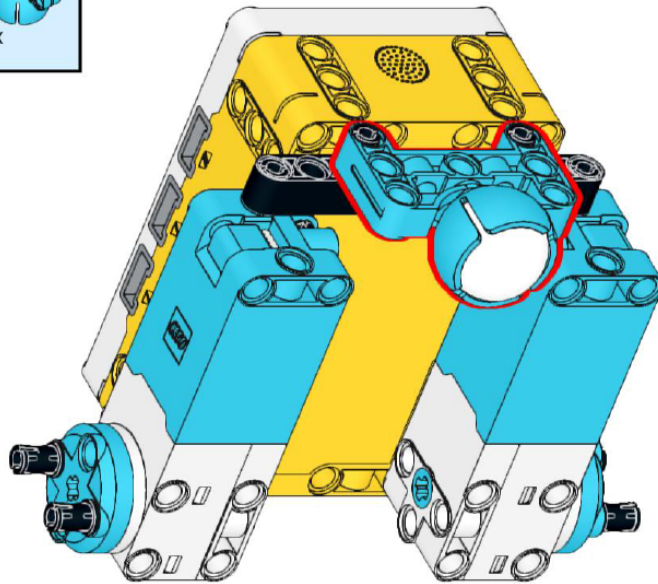
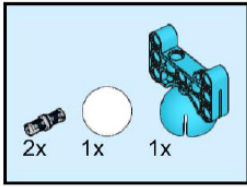

6

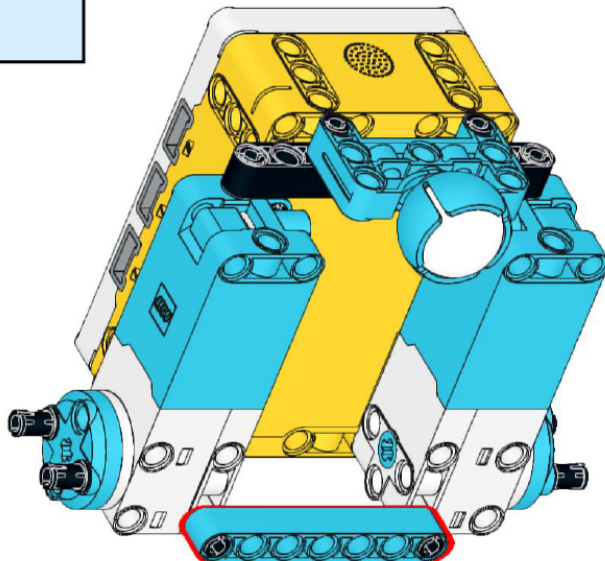
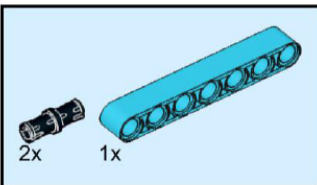



7

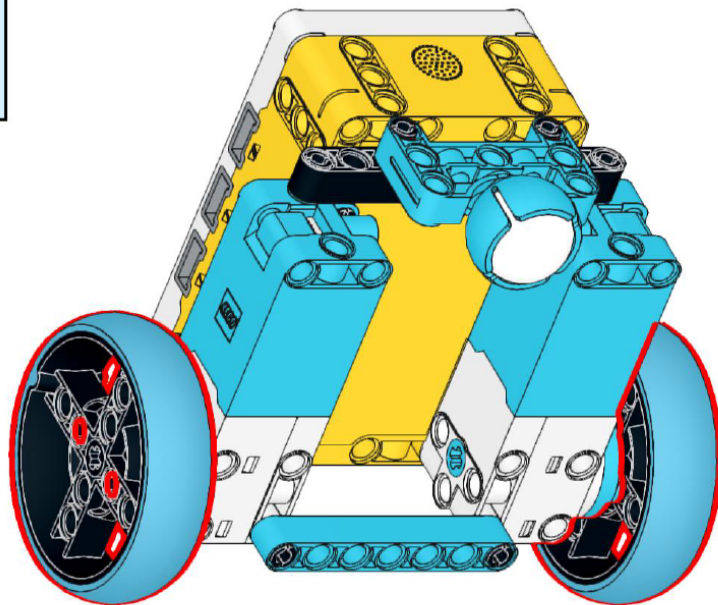

8

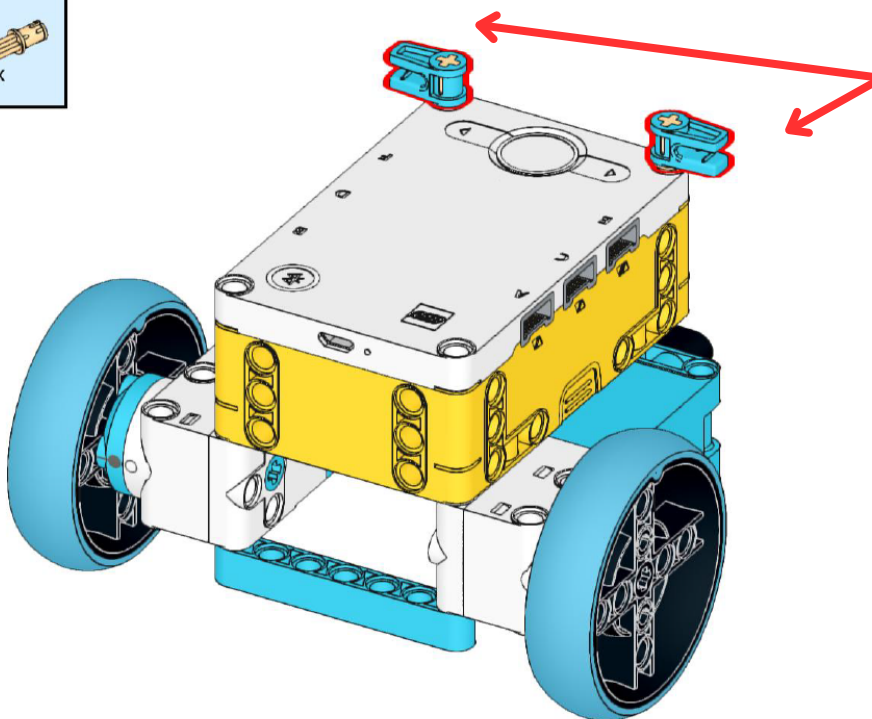
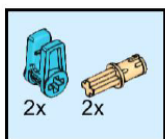

Passez les câbles dans ces connecteurs





9

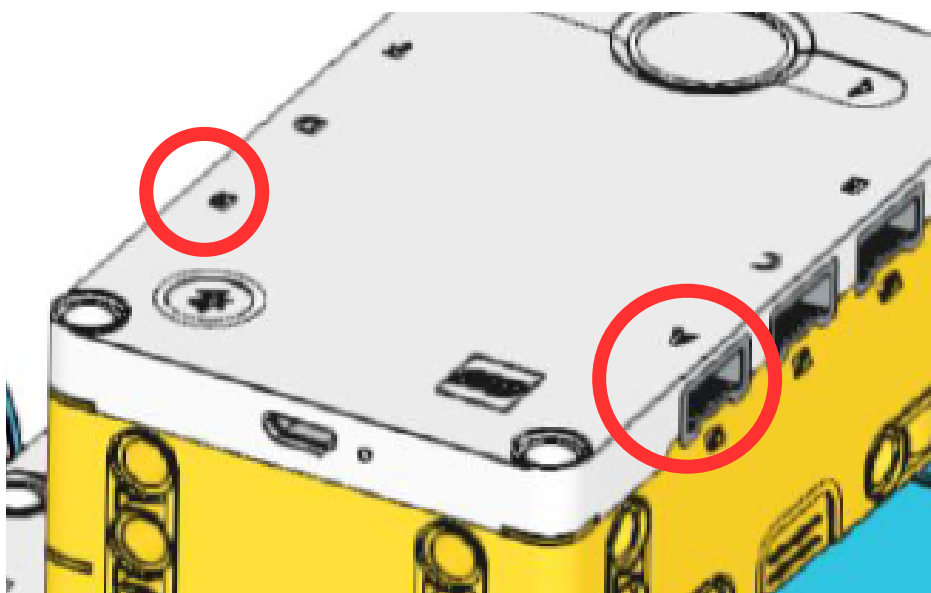

Branchez  
les câbles  
dans les  
ports A et  
B

10

Arrière du  
robot

Devant du  
robot

