

INSTRUCTIONS DE MONTAGE POUR LA BASE MOTRICE À ROUES NOIRES

Projet robotique en mathématique

Produit par :
Maxime Poirier et Marie-Pier Bécard





1

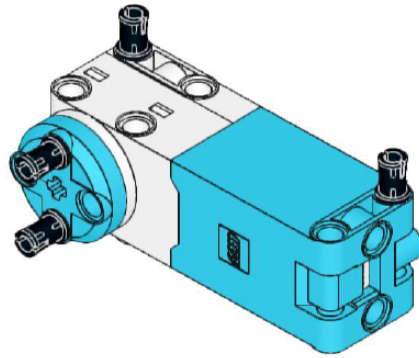
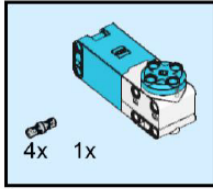

2

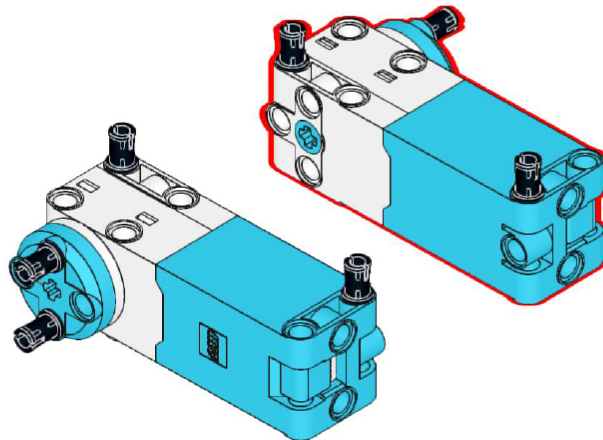
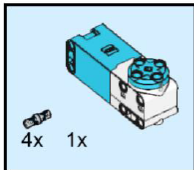



3

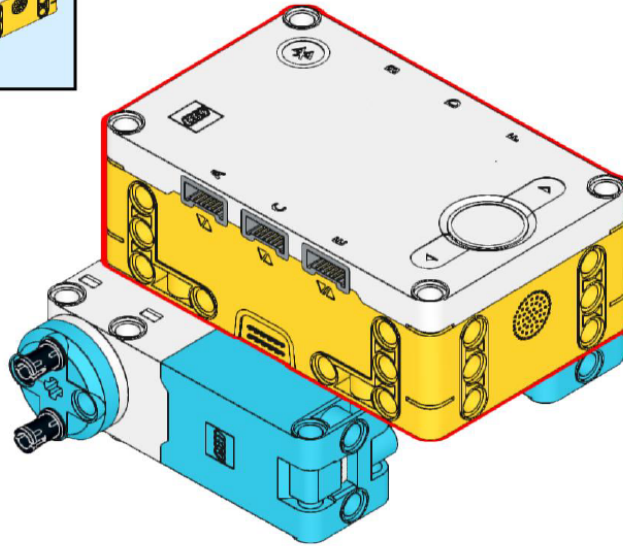
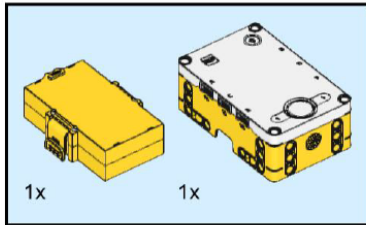

4

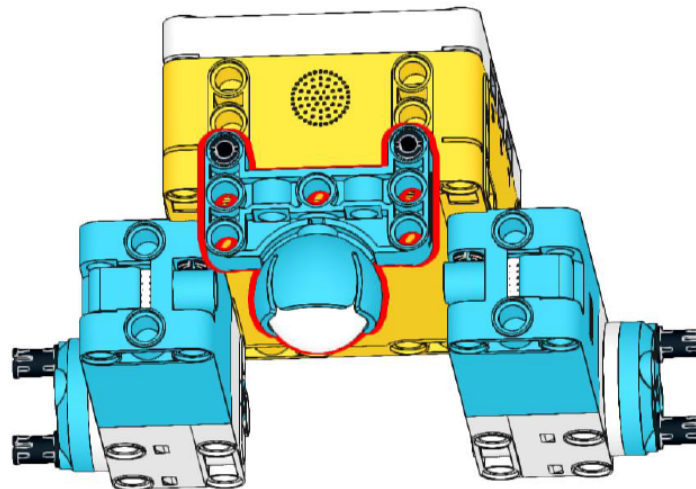
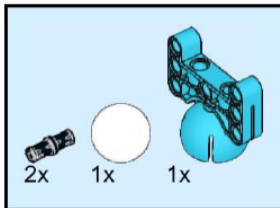



5

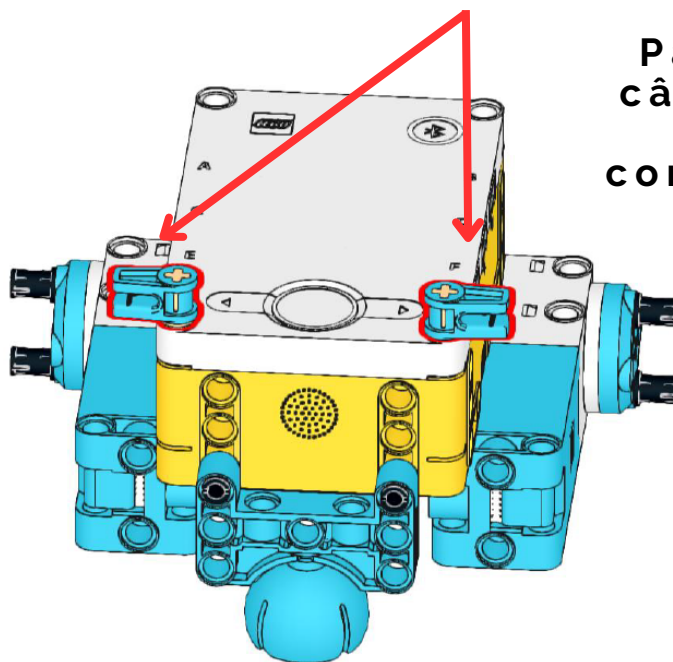
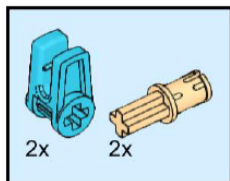

Passez les câbles dans ces connecteurs

6

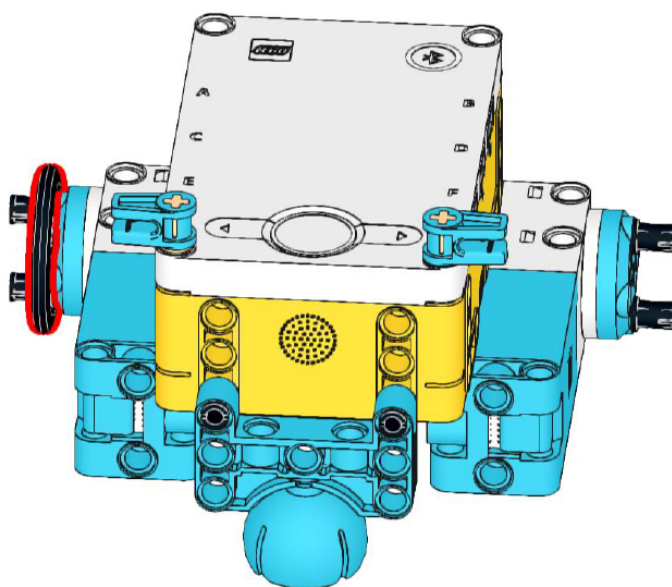
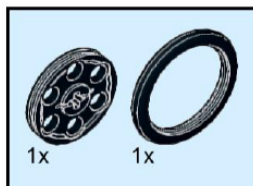



7

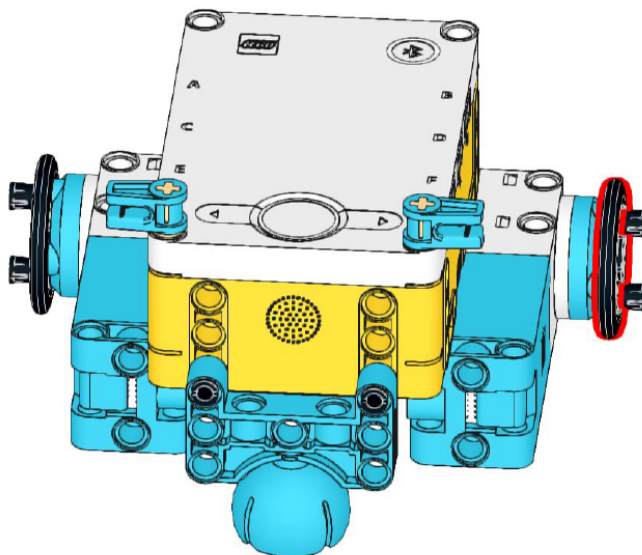
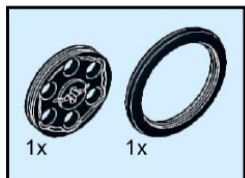

8

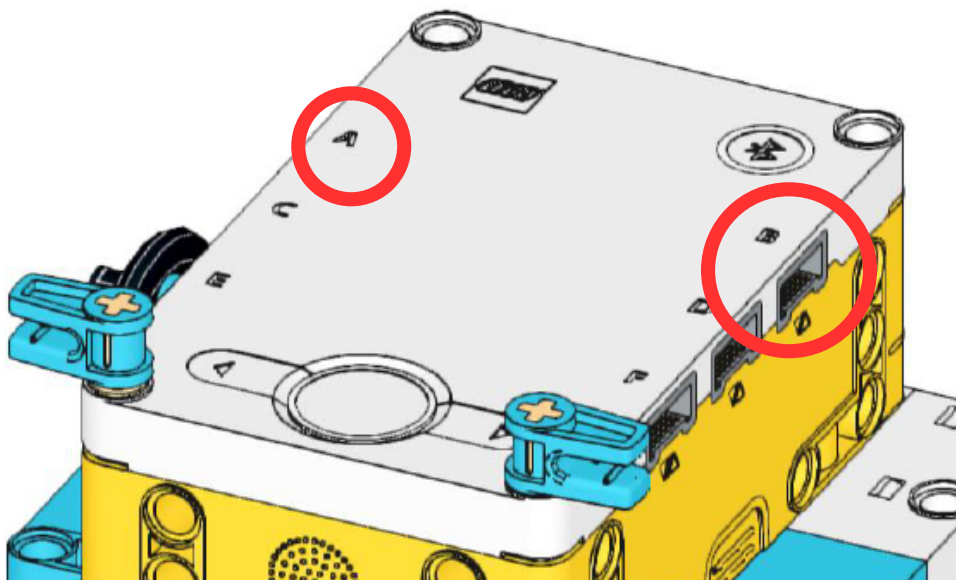

**Branchez
les câbles
dans les
ports
A et
B**





9

Arrière du robot

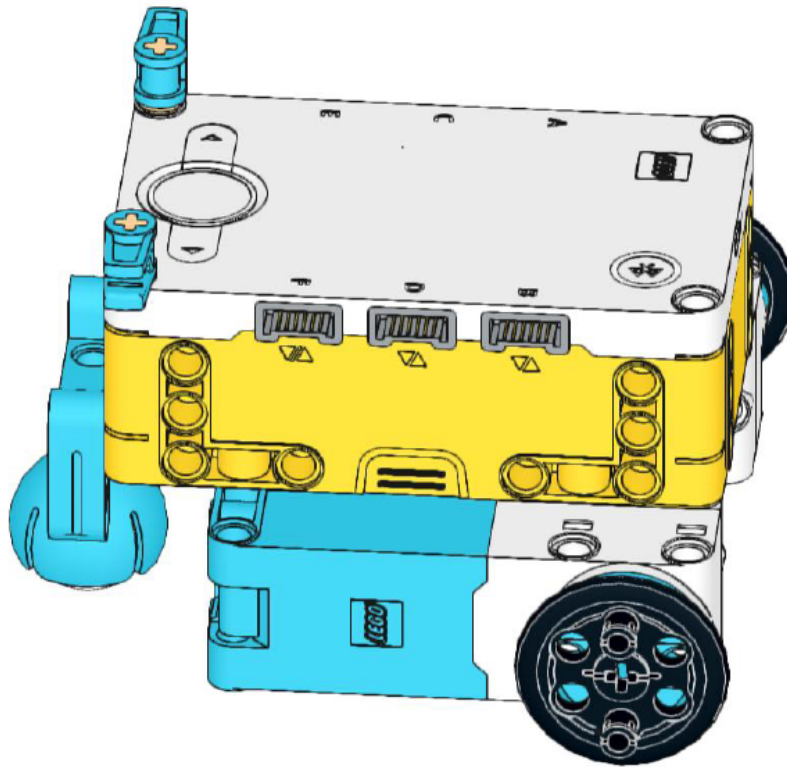

Devant du robot

